

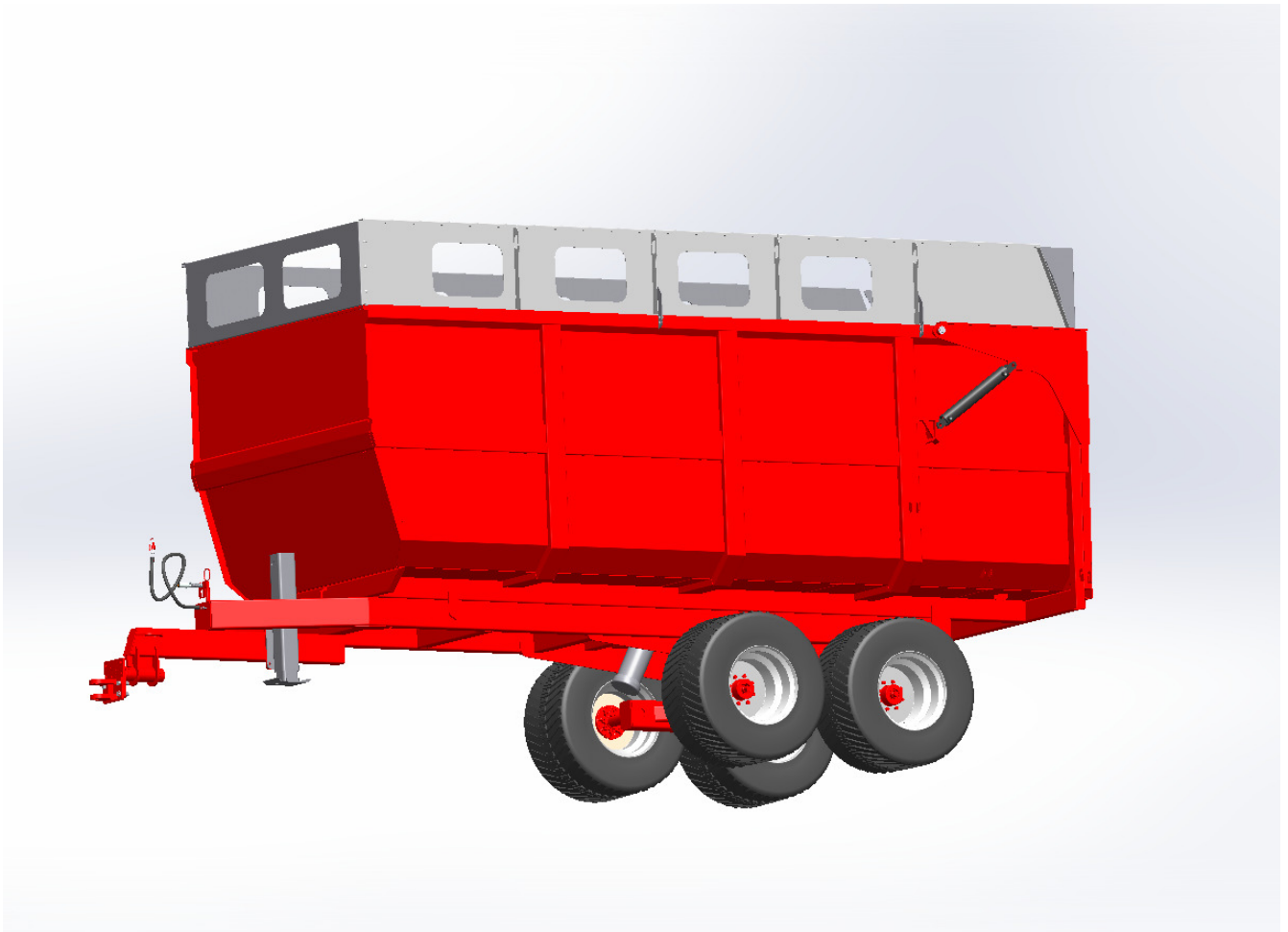

Service manual and parts
Forage Box
8x18 et 8x20



Les Équipements Woody inc. 205, rue commercial Saint-Odilon, Québec G0S3A0

Tél./ Tel. 418-464-2748 Fax. 418-464-2746

Email: ewoody@sogetel.net / Website : www.equipementswoody.com / Facebook: Les Équipements Woody



Les Équipements Woody Inc.

Owners: Jérôme et Sébastien Labbé

205 rue commerciale
St-Odilon de cranbourne
Beauce-Nord
Québec, Canada
G0S 3A0

Phone. (418) 464-2748

Fax. (418) 464-2746

E-mail: ewoody@sogetel.net

Web site: www.equipementswoody.com

Facebook: Les Équipements Woody

Les Équipements Woody Inc.

©All Rights Reserved: Woody Equipment inc. of Saint-Odilon-de -ranbourne.
No part of this manuel may be reproduced in any form without the written permission of
Woody Equipment Inc.



Table of contents

Introduction.....	1
Warning.....	2
Dump trailer, model 8x18 part list.....	3
Dump trailer, model 8x18 part list.....	4
Dump trailer, model 8x20 part list.....	5
Dump trailer, model 8x20 part list.....	6
Wheel hubs characteristics.....	7
Safety operation.....	8
Safety instructions.....	9-14
Warranty.....	15-16



Introduction

Congratulations on your purchase of a Woody Dump Trailer. Woody Equipment designs and manufactures equipment according to very strict criteria. This equipment is intended for professional use in the agricultural and forestry sectors.

Even if you have experience with this type of product, we recommend that you read these instructions carefully. These instructions contain important information on safety and efficiency and to ensure the validity of the factory guarantee.

Woody Equipment reserves the right to modify and / or improve its equipment and maintenance instructions, as well as to revise data without notice.

Write down the serial number, model number, purchased date, dealer name, and sales representative's name. Keep this information available for ordering parts as well as for any technical assistance or warranty issue.

Serial number	
Model number	
Delivery date	
Distributor	
Sales representative	



Warning

The following symbols used in this manual are to warn the operator of the dangers connected to the use of this machinery. Follow the safety instructions to avoid any risk of serious injury or death.

	AVERTISSEMENT
	CHUTE DE LA CHARGE OU DES MÂTS Peut causer de graves blessures ou la mort. Ne jamais déplacer la charge ou les mâts au-dessus du personnel.
	WARNING
	FALLING BOOM OR LOAD Can cause severe injuries or death. Do not move booms or load over people.
<small>AVERTISSEMENT - CHUTE DE LA CHARGE</small>	

	AVERTISSEMENT
	RISQUE D'ÉCRASEMENT Les stabilisateurs peuvent causer de graves blessures ou la mort. Gardez le personnel éloigné des stabilisateurs.
	WARNING
	CRUSHING HAZARD Stabilizers can cause severe injuries or death. Keep bystanders away from stabilizers.
<small>AVERTISSEMENT - RISQUE D'ÉCRASEMENT</small>	

	AVERTISSEMENT
	MACHINE INSTABLE Toujours opérer la chargeuse avec les stabilisateurs abaissés sur un sol ferme et au niveau. Assurez-vous d'avoir une stabilité adéquate.
	WARNING
	UNSTABLE MACHINE Do not operate loader without lowering the stabilizers on firm level ground and checking for adequate stability.
<small>AVERTISSEMENT - MACHINE INSTABLE</small>	

	DANGER
	ÉLOIGNEZ-VOUS STAY AWAY
<small>DANGER - ÉLOIGNEZ-VOUS</small>	

	AVERTISSEMENT
<small>Chaque opérateur de cette chargeuse doit être qualifié et entraîné avant d'opérer ce équipement. Observez les lois fédérales et provinciales sur les règlements de sécurité. Consultez votre manuel de travail particuliers à effectuer. Ne jamais dépasser les spécifications techniques recommandées de la chargeuse ou de l'accessoire. Il est important de suivre les instructions sur les zones de sécurité. L'opérateur travaillant dans la zone de danger de la chargeuse ou dans les modifications tactiques, sans des mesures de sécurité appropriées, peut en résulter.</small>	
	WARNING
<small>Any operator of the loader must be fully trained and qualified to do so. Observe all state or provincial safety regulations relating to the particular work being performed. Never exceed recommended technical specifications of the loader or its attachments. Injury, including death may result from failure to follow this warning and the information contained in the loader operator's manual/technical specifications sheet.</small>	
<small>AVERTISSEMENT - ZONE DE DANGER</small>	

DANGER 20M ZONE AREA



**Part list
Gravel Box
8x18 50-015**

Item	Part number	Description	Quantity
1	50-015-01	Frame 8 x 18 HD	1
2	59-015-13	Gravel box 8 x 18	1
3	59-120-06	Tandem 59-120-06 Hub 12000 Lb	2
4	140040-108- 101700- 101700	Hose Assembly 1/2" - 108" Long	1
10	86-31-124- F12-00	Shaft 1 15/16" O.D.	2
13	59-124-033	Tandem axle	1
17	310500	Light 6.5 oval, KT3260A (YELLOW)	2
18	310510	Light 6.5 oval, KT3260R (RED)	2
21	310820	7-pin connector on trailer side	1
22	301012	Bolt 7/8"-9 x 3" Long	4
25	302100	Tire 550-45-22.2 8 nuts	4
27	50-015-12	Rear Tilt Panel	1
28	50-015-10	Pivot pin rear panel	2
32	59-000-36	Hydraulic jack assembly	1
33	50-015-06	Extension panel for 8 x 18 left side	1
34	50-013-050	Back door panel	1
35	50-015-07	Extension panel for 8 x 18 right side	1
36	50-015-052	Rear door extension panel	1
37	121166	Telescopic cylinder	1
38	50-015-03	Cylinder pivot box	1
39	59-015-14	Cylinder locks	2
40	120501	Cylinder CL 3020	1
44	50-015-062	External riser stopper	4
45	50-015-063	Side panel reinforcement	2
46	50-015-082	Rear panel reinforcement	2

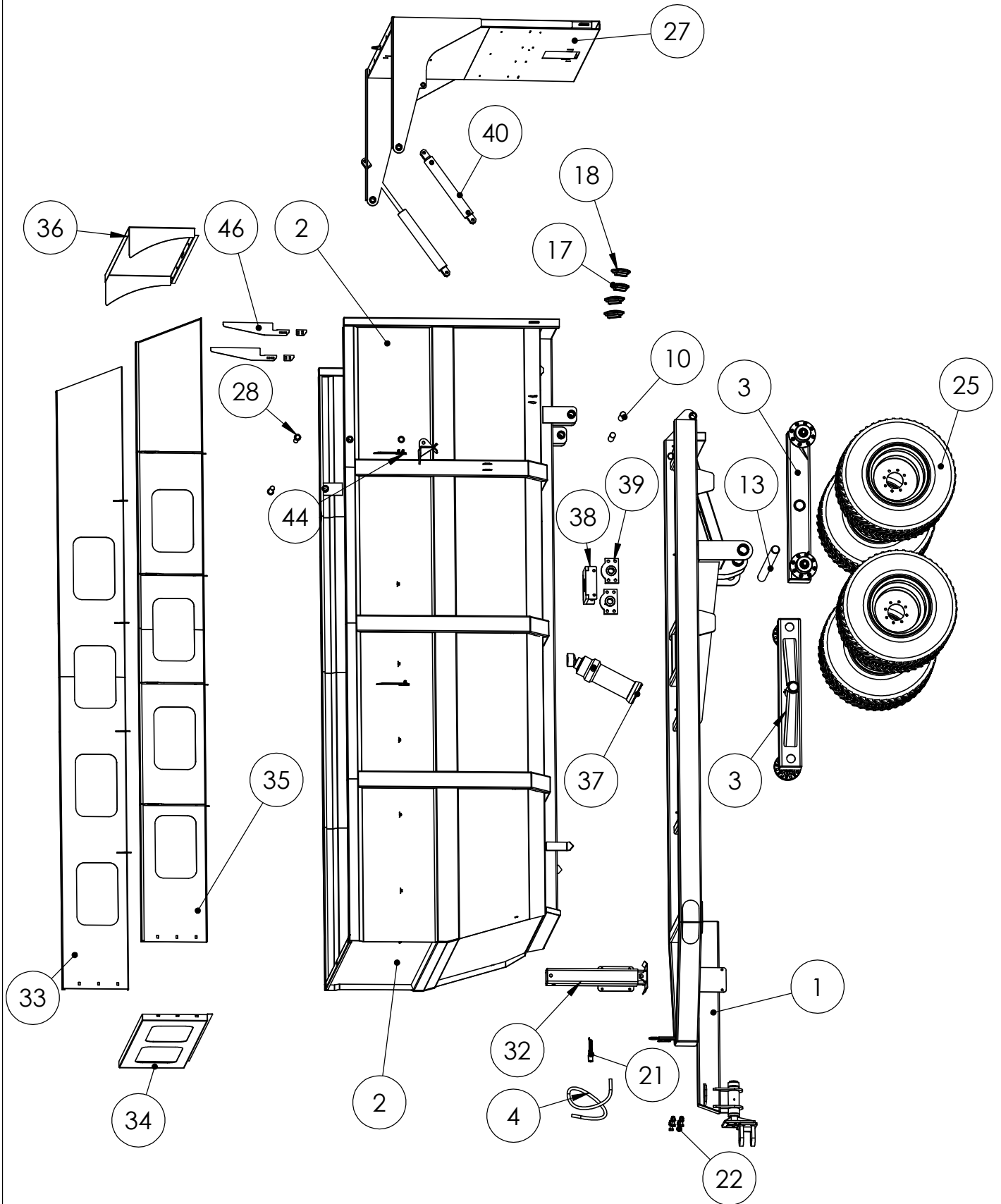



**Parts List
Gravel Box
Operator Manual**

Item	Part number	Description	Quantity
1	50-016-01	Frame 8 x 20 HD	1
2	59-016-13	Gravel box 8 x 20	1
3	59-120-06	Tandem 59-120-06 Hub 12000 Lb	2
4	140040-108-101700-101700	Hose Assembly 1/2" - 108" Long	1
10	86-31-124-F12-00	Shaft 1 15/16" O.D.	2
13	59-016-035	Tandem axle	1
17	310500	Light 6.5 oval, KT3260A (YELLOW)	2
18	310510	Light 6.5 oval, KT3260R (RED)	2
21	310820	7-pin connector on trailer side	1
22	301012	Bolt 7/8"-9 x 3" Long	4
25	302100	Tire 550-45-22.2 8 nuts	4
27	50-016-12	Rear Tilt Panel	1
28	50-015-10	Pivot pin rear panel	2
29	50-012-073	Washer	2
32	59-000-36	Hydraulic jack assembly	1
33	50-016-06	Extension panel for 8 x 20 left side	1
34	50-015-05	Back door panel	1
35	50-016-07	Extension panel for 8 x 20 right side	1
36	50-015-052	Rear door extension panel	1
37	121166	Telescopic cylinder	1
38	50-015-03	Cylinder pivot box	1
39	59-015-14	Cylinder box	2
40	120501	Cylinder CL 3020	2
41	50-015-062	External riser stopper	6
42	50-015-082	Rear panel reinforcement	2

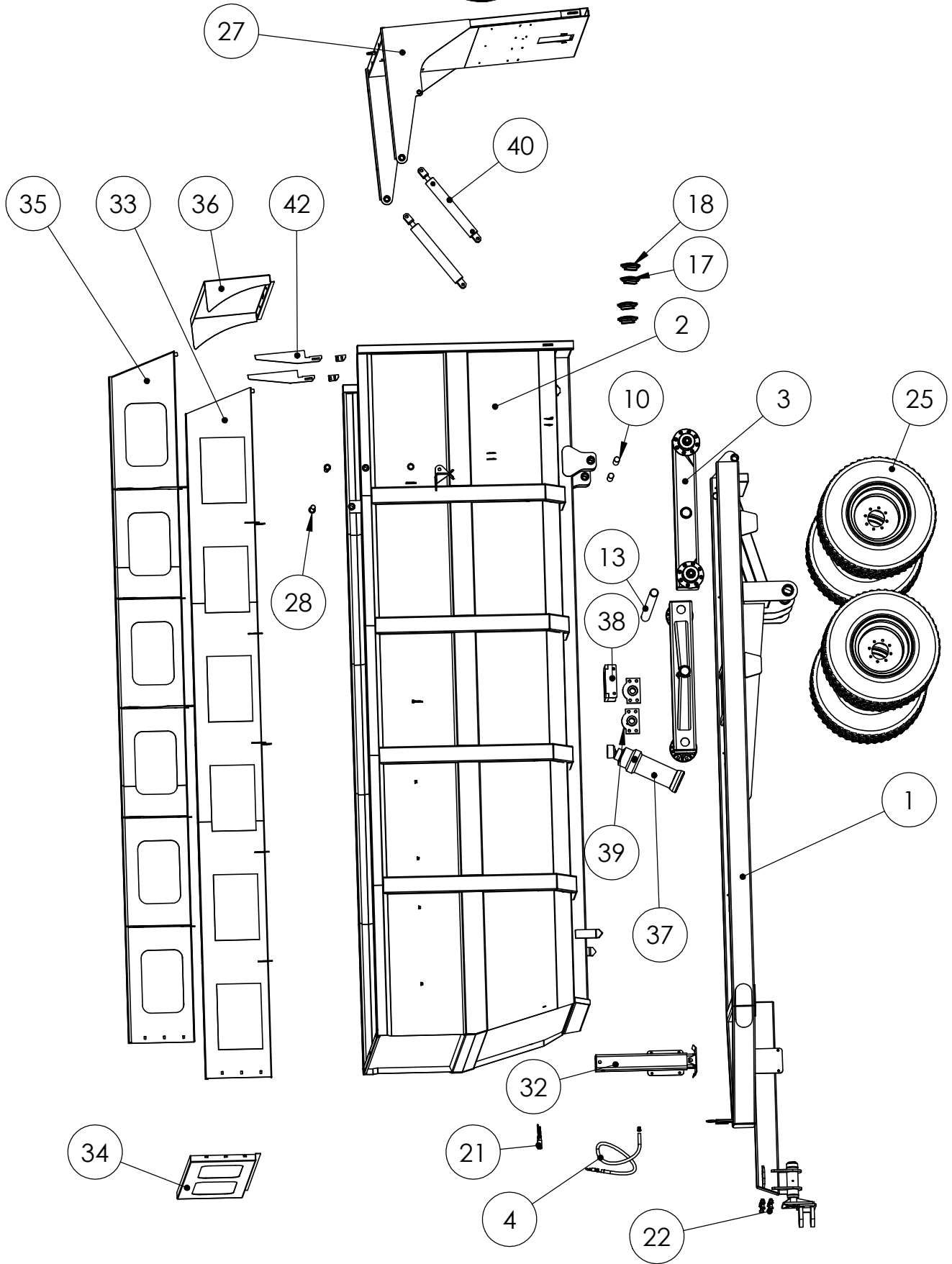

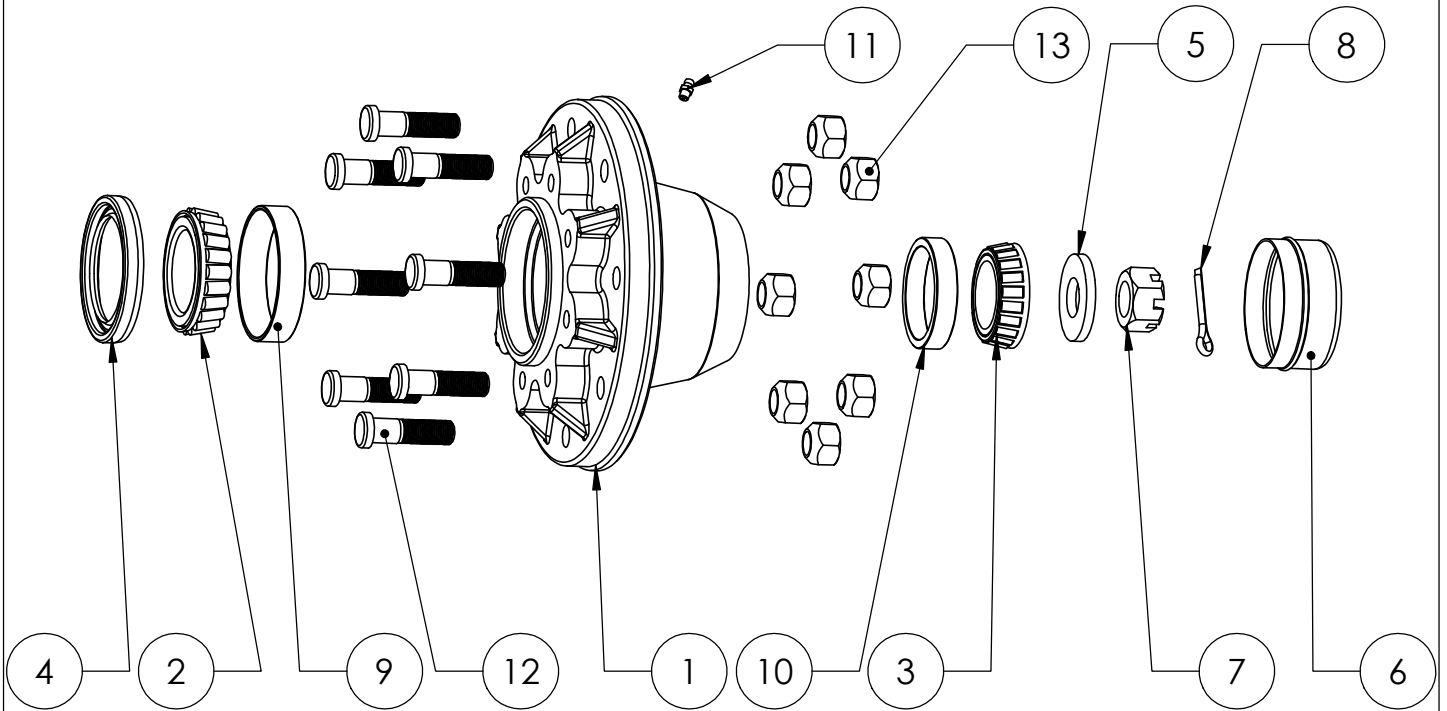

Items	1250 lbs	3500 lbs	5000 lbs	8000 lbs	10000 lbs	12000 lbs	16000 lbs
1	306001	306100	306201	306300	306401	306501	306801
2	306003	306103	306203	306304	306403	306503	306803
3	306003	306104	306204	306303	306404	306504	306804
4	306005	306107	306207	306340	307407	306507	306807
5	n/a	306113	306113	306313	n/a	n/a	n/a
6	306006	306108	306208	306308	306308	306508	306808
7	306007	306109	306309	306309	306409	306509	306809
8	306008	306110	306210	306310	306310	306510	306810
9	306004	306105	306205	306305	306405	306505	306805
10	306004	306180	306206	306306	306406	306506	306806
11	n/a	n/a	310020	310020	n/a	n/a	n/a
12	n/a	306111	n/a	306310	306311	306511	306811
13	306010	306010	n/a	306312	306312	306512	306812



Operation

General safety rules:

Read this instruction manual carefully before using the dump trailer. The technical data in this manual contains important information.

Improper use can result in injury and damage to the equipment.

Woody dump trailers are intended for normal use in the agricultural and forestry sectors. They must be used only by persons trained in the handling of this type of machinery.

Before connecting the dump trailer to the tractor's hydraulic system, you must read the tractor's instruction manual to ensure proper connections.

- Be extremely careful when connecting the dump trailer to the tractor or the trailer to the tractor, as well as when detaching it.
- When operating, make sure everyone remains in the safety zone, outside of the loader risk area. The user and operator of the excavator must have full visibility of the work area.
- When operating, do not insert your hand or any other part of your body into the machine or under the load. Do not risk getting stuck between the different parts of the dump trailer or between the tractor and the dump trailer.
- Do not forget to lower the gravel dump box before moving the trailer.
- When loading, always engage the tractor handbrake.
- Never use the dump trailer to pull, push or hit.
- Be particularly careful when loading and unloading heavy materials.
- Never use the loading device during transport.
- To stop the machine, turn off the engine, engage the handbrake and remove the key from the ignition to prevent unauthorized use.
- The dump trailer is not intended for transporting people.
- Be very careful when loading or unloading near high voltage lines. Keep a safe distance from live cables.



Safety Instructions

If the overload protection of the hydraulic system is not properly adjusted or certain system functions are altered, safety cannot be ensured.

Always check that any unauthorized personnel remains outside the work risk area.

Make sure that the tractor and trailer are always on firm ground so that there is no risk of overturning when loading or unloading.

Make sure you always have a visual view of the work area.

Do not work in conditions where you may get your fingers caught or hurt yourself.

When there is a risk of overturning, immediately lower the gravel box with the control lever.

Hold the lever in this position until the load is on the ground. Do not interrupt the lowering movement as the risk of overturning will increase if the load stops abruptly.

If the tractor rolls over, follow the instructions in the cab. Do not jump out of the cab. You could end up under the load during a fall or under the tractor.

Cracks in hydraulic hoses

In the event of pressure loss in the hydraulic fluid or cracks in the hydraulic hoses, you must immediately shut down the tractor engine and lower the dump trailer gravel box to the ground. Stop the hydraulic flow.

Repair the leak

If the main pressure hose is cracked, you must interrupt the oil flow by disconnecting the lever control associated with the tractor's hydraulic distributor or by shutting off the engine with the OFF button.



Safety Instructions

Driving on the Road

Observe the following instructions to avoid any risk of accident.

Position during Transport

Make sure that the dump trailer is firmly attached to the transportation trailer, so that it does not fall off during transport.

Make sure that no additional equipment connected to the dump trailer is likely to cause an accident during transport.

Control is Important

You must constantly be in control of the dump trailer at all times and in all situations.

Check that the "slow vehicle" plate and the reflective signals are correctly positioned. Check if the trailer lights are functioning correctly and check the tire pressure.

The total permitted weights (in particular the weight of the axle) and the transport dimensions must never be exceeded.

You must adapt your speed to the driving situation. Drive with caution when one side is tilted, as well as on sloping ground.

There is a risk of over turning.

Respect the laws of the road and applicable regulations.

The braking distance of a tractor equipped with a trailer is longer than for other vehicles, beware of the risk of skidding and check for irregularities in the road.

Secure the load and other loose parts securely.

Oil and Grease Caution

Avoid any oil or grease contact with the skin during maintenance. Wear appropriate protective clothing.

Never wash your hands with lubricating oil or grease. It may damage your skin. If your skin is irritated after contact with oil or grease, contact a doctor immediately.

When servicing, waste oil should be disposed of in accordance with local regulations.



Safety Instructions

Welding Repair

- If a repair or modification requires the welding of certain parts, you must first contact your dealer for necessary instructions. Improper welding or negligence during welding can cause sudden machine breakdowns.

Working in Extreme Conditions

- The recommended ambient temperature for the operation of this machine is between -20 °C and + 30 °C. Low or high temperatures result in increased wear and stress on joints and hoses. In addition, steel wears faster, and cracks can occur.
- When working in extreme conditions, reduce loads to prevent damage. In case of low temperature let the hydraulic oil circulate freely during several minutes. Then operate each function several times to soften the joints and hoses before applying full pressure. When it is extremely hot, pay attention to the oil temperature. A temperature above 80 °C alters the properties of the oil and damages joints and hoses.

Maintenance / Service

- Regular maintenance and service ensure optimal and cost effective operation.
- Note: Failure to follow the instructions in this manual will void all warranties related to this dump trailer. Regular and proper maintenance are a prerequisite for warranty coverage.

Maintenance and Servicing Safety Instructions

- Read the instructions before servicing the machine. Each maintenance task requires reading and following instructions. Maintenance and lubrication should be done at the recommended intervals.
- Always use tools suitable for the maintenance / servicing tasks involved. Wear protective clothing and glasses.
- Shut off the tractor engine and remove the ignition key. If the engine has to run during certain maintenance operations, please stay away from any moving parts of the machine.
- Be extremely careful with pressurized oil. Oil under high pressure easily penetrates the skin. In case of accident, consult a doctor immediately.



Safety Instructions

Maintenance and Servicing Safety Instructions (...continued)

- Hot oil can cause burns. Inhalation of hot oil vapor can cause breathing difficulties.
- If a hose bursts and you get oil on your skin, it is not dangerous. However, avoid oil contact with eyes and nose. If you get oil in your eyes or in your respiratory tract, contact a doctor immediately.
- Keep explosive and flammable liquids away from sparks and open flames.

Daily inspections

It is important to inspect the equipment daily. If you notice a defect, you must repair it immediately.

- When under load pressure, worn bolts can provoke a risk of rupture. If cracks are detected on the loader, any operation in progress must be stopped immediately.
- Damaged hoses must be replaced immediately. Check for leaks. Oil leaks create a risk of accidents and can harm the environment.
- Check the bolts and tighten the bolts if necessary.
- Perform the various movement patterns of the loader to verify that all functions are intact and working properly.

Safety Instructions

Greasing schedule

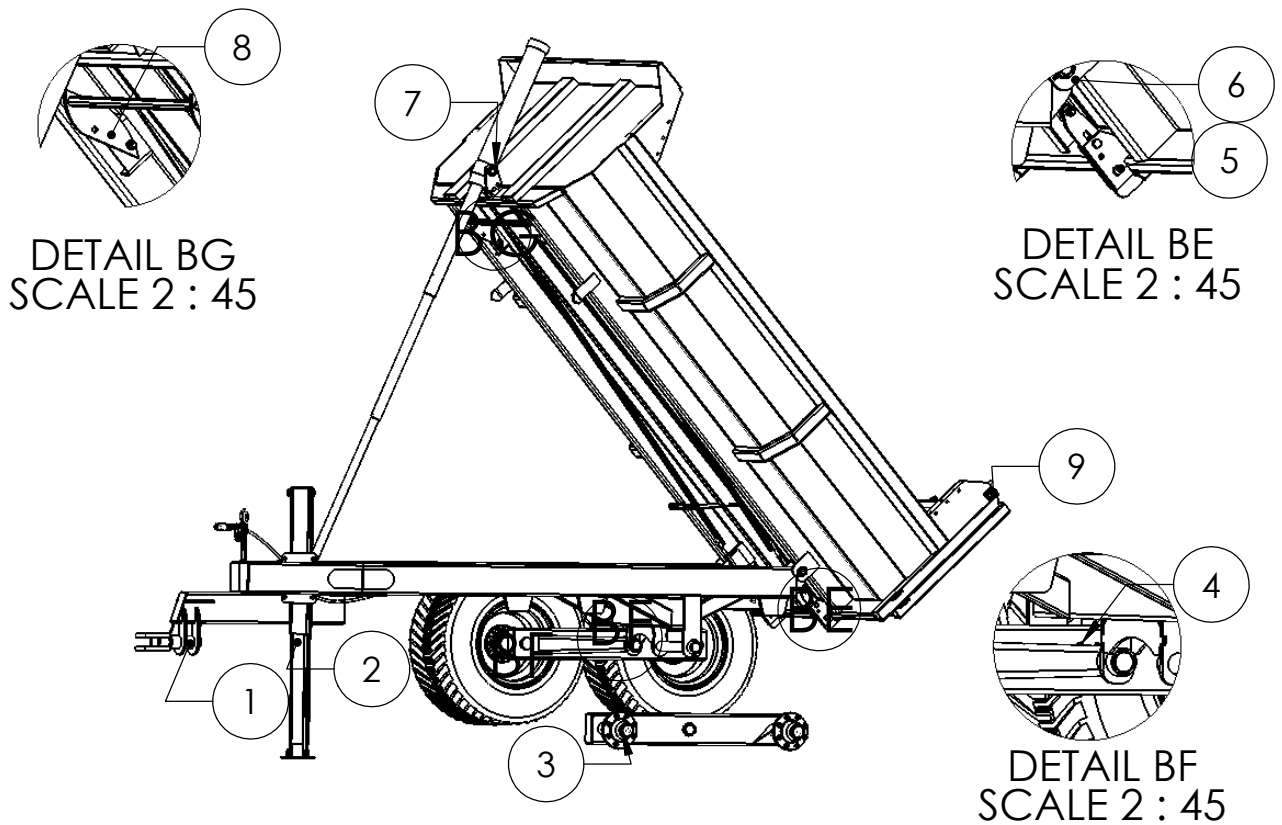

ITEM	Greasing point	Lubricating oil	Greasing interval Hourly / yearly
1	Swivel hitch	Bushing grease	Every 5 hours
2	Jack	Bushing grease	Once a year, generously
3	Hub	Bushing grease	Every 10 hours
4	Tandem pivot	Bushing grease	Every 5 hours
5	Trigger slider	Bushing grease	Once a year, generously
6	Gravel box pivot	Bushing grease	Every 5 hours
7	Cylinder pivot	Bushing grease	Every 5 hours
8	Trigger slider pivot	Bushing grease	Once a year, generously
9	Panel pivot	Bushing grease	Every 5 hours



Safety Instructions

Storage

If you plan to stop using the dump trailer for a long period of time, it should be cleaned carefully. Note that high pressure cleaning is not recommended! After cleaning, make a visual inspection for any cracks (if you find any, you must have them repaired before the next use of the loader) all grease nipples must be lubricated. The grease is used to evacuate water and thus neutralize corrosion and wear.

- Store the dump trailer under a roof. If this is not possible, cover it with a tarpaulin.

Note: A stored trailer is not a play area for children.



1-YEAR LIMITED WARRANTY

Warranty Qualifications

All Products manufactured by Woody and used for domestic purposes (excluding commercial, industrial or abusive use) are covered by a one (1) year warranty applicable from the purchase date, except in particular cases when the warranty might be modified according to adjustments specified on the sales contract.

The warranty extends only to the original purchaser of the Product and not to other purchasers or transferees unless agreed to in writing by Woody that the mechanical and electrical components will be free of defects in material and workmanship for the warranty period. The warranty covers all the parts of the new Product, except the hydraulic hoses, the hydraulic fittings and the electrical wires, and includes the labor performed by Woody or by a Woody authorized Dealer.

Warranty Repair and Replacement Service

All warranted repairs must be performed by Woody or by an authorized Dealer with the written consent of Woody; otherwise the warranty will be voided. Woody reserves the right to either repair or replace, without cost to the buyer any part judged defective on grounds of defective materials or workmanship. It also reserves the right to determine if the defect resulted from lack of maintenance or incorrect or abusive use of the Product.

In the event of any failure caused by a defect in material or in factory workmanship covered by this warranty, the Buyer shall: (1) notify Woody of the nature of the problem without delay; (2) stop using or operating the Product unless authorized in writing by Woody.

Warranty service shall be performed at the point of purchase of the Product either by Woody or by a Dealer using parts provided by Woody.

If the Product was purchased directly from Woody, the Buyer shall return either the Product or the defective parts "prepaid" to Woody without delay. If Woody deems that the parts are in fact defective, it shall repair or replace the parts and, when the Product is returned to Woody, install them free of charge to the Buyer.

If the Product was purchased from a Dealer, Woody shall provide the replacement parts to the Buyer through the intermediary of the Dealer. The Dealer shall install the parts and return the replaced parts to Woody, "prepaid" by the Buyer, within thirty (30) days of the repairs. The parts and their installation shall be without charge to the Buyer providing that the replaced parts are proven defective to Woody's satisfaction.

In all cases, all costs related to the transportation of parts or of the Product to and from Woody or the Dealer, any premium charged for overtime labor requested by the Buyer or for any service and/or maintenance shall be the sole responsibility of the Buyer.

All parts replaced under the warranty shall remain the property of Woody.

If the Buyer fails to follow any of the above procedures or if the parts are not proven to be defective to Woody's satisfaction, the Buyer shall not benefit from the warranty.



No Dealer Warranty

The Dealer has no authority to make any representation or promise on behalf of Woody, or to modify the terms or limitations of this warranty in any way.

Warranty Exclusions

This warranty does not cover the following:

Product needs periodic parts and service to perform well. This warranty does not cover repair when normal use has exhausted the life of a part or the equipment as a whole or by lack of reasonable and proper maintenance, by lack of proper protection during storage, by failure to follow operating instructions and/or failure to operate the Product according to the specifications outlined by Woody.

This warranty does not apply to damage caused to the Product or machinery by the Buyer or Dealer during installation of the Product or due to improper installation of the Product.

This warranty will not apply to parts and/or labor if this Product is deemed to have been misused, neglected, involved in an accident, abused or defects caused by any alteration or modification of the Product not approved in writing by Woody.

This warranty does not cover travel time and does not cover any other transportation-related costs for warranty repairs or for any other expertise.

Other Exclusions

This warranty excludes:

- Cosmetic defects such as paint, decals, etc.
- Any damage resulting from overturning the machine.
- Failures due to acts of God and any other major force events beyond Woody's control.
- Problems caused by parts that are not original Woody parts.
- Certain parts are guaranteed by their respective manufacturer.

Limits of Implied Warranty and Consequential Damage

Woody disclaims any obligation to cover any material or personal damages, including loss of time, loss of income use of this Product, replacement rental, freight or any other damages caused by a defective Product or any incidental or consequential claim by anyone from using this Product.