

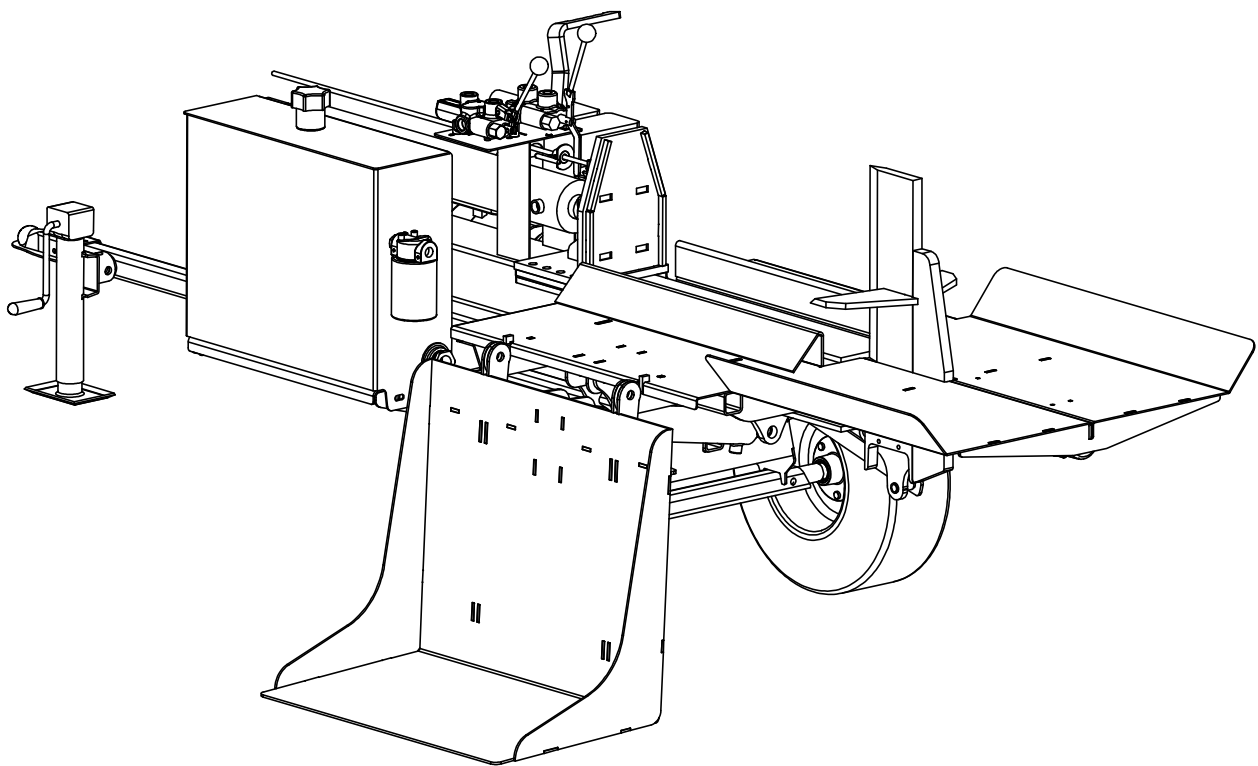

Parts Manual Woody Wood Splitter

Models: 40-30 and 40-36 4mcx



Woody Equipment inc. 205, rue commerciale Saint-Odilon-de-Cranbourne, Québec, Canada G0S3A0

Tel. 418-464-2748 Fax. 418-464-2746

Email: ewoody@sogetel.net Website: www.equipementswoody.com Facebook: Les Équipements Woody



Woody Equipment Inc.
Owners: Jerome et Sebastien Labbe

205 rue commerciale
St-Odilon de cranbourne
Beauce-Nord
Québec, Canada
G0S 3A0

T. (418) 464-2748

F. (418) 464-2746

Email : ewoody@sogetel.net
Website: www.equipementswoody.com
Facebook: Les Equipements Woody

Woody Equipment Inc.

© All Rights Reserved: Woody Equipment Inc. of Saint-Odilon-de-Cranbourne.
No part of this manuel may be reproduced in any form without the written permission
Of Woody equipment Inc.



Table of Contents

Introduction.....	1
Caution.....	2
Characteristics of the splitter.....	3-4
Parts.....	5
General security.....	6
General maintenance.....	7
Guarantee.....	8-9



Introduction

Congratulations on your purchase of a Woody Wood Splitter. Woody Equipment designs and manufactures equipment according to very strict criteria. This equipment is intended for professional use in the agricultural and forestry sectors.

Even if you have experience with this type of product, we recommend that you read these instructions carefully. These instructions contain important information on safety and efficiency and to ensure the validity of the factory guarantee.

Woody Equipment reserves the right to modify and / or improve its equipment and maintenance instructions, as well as to revise data without notice.

Write down the serial number, model number, purchased date, dealer name, and sales representative's name. Keep this information available for ordering parts as well as for any technical assistance or warranty issue.

Serial number	
Modele	
Purchased date	
Dealer	
Sales representative	



Warning

The following symbols used in this manual are to warn the operator of the dangers connected to the use of this machinery.

Follow the safety instructions to avoid any risk of serious injury or death.



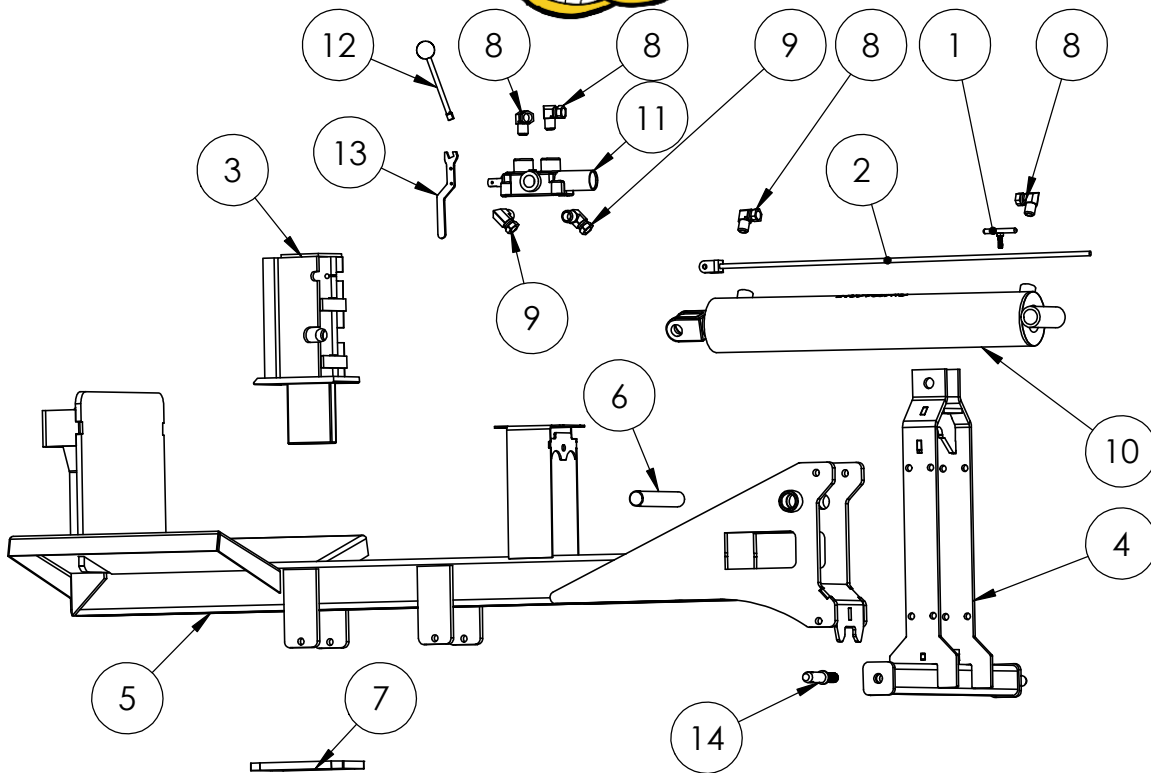

Parts liste
40-24 three points/ 40-30 three points

No.	Number of piece 40-24	Number of piece 40-30	Name	Qty
1	55-001-10-PR	55-001-10-PR	Trigger adjustment handle	1
2	55-001-09-PR	55-006-02-PR	Trigger rod	1
3	55-001-06-PR	55-001-06-PR	Splitter	1
4	55-001-02-PR	55-001-02-PR	three point hitch	1
5	55-002-03-PR	55-006-01-PR	Frame	1
6	86-20-130-E08-00	86-20-130-E08-00	Rod 1 1/4" O.D.	1
7	55-001-020-PR	55-001-020-PR	Fixing plate	1
8	9405-08-08	9405-08-08	Elbow 90° NPSM Fem SWI x NPT Male - 1/2" x 1/2"	4
9	9405-08-12	9405-08-12	Elbow 90° NPSM Fem SWI x NPT Male - 1/2" x 3/4"	2
10	CU4024-0317	CU4030-1244	Hydraulic cylinder 4" Dia. x 24" Stroke	1
11	55-001-18-PR	55-001-18-PR	Hydraulic valve	1
12	-----	-----	Valve handle	1
13	55-001-044-PR	55-001-044-PR	Automatic trigger plate	1
14	310860	310860	Pin three point 7/8	1



4MCX Wood Splitter Features

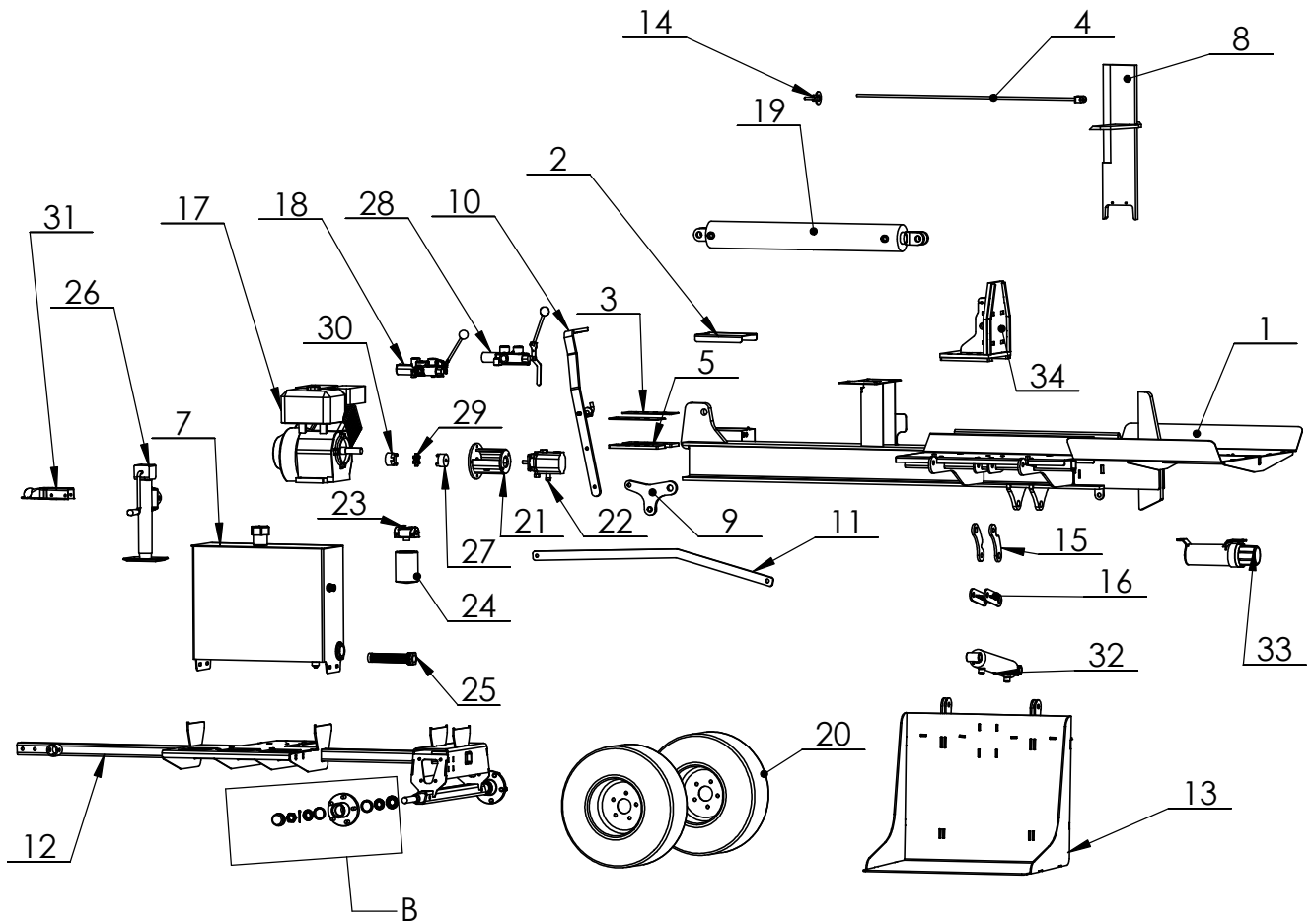

DÉTAIL B
ECHELLE 1 : 3

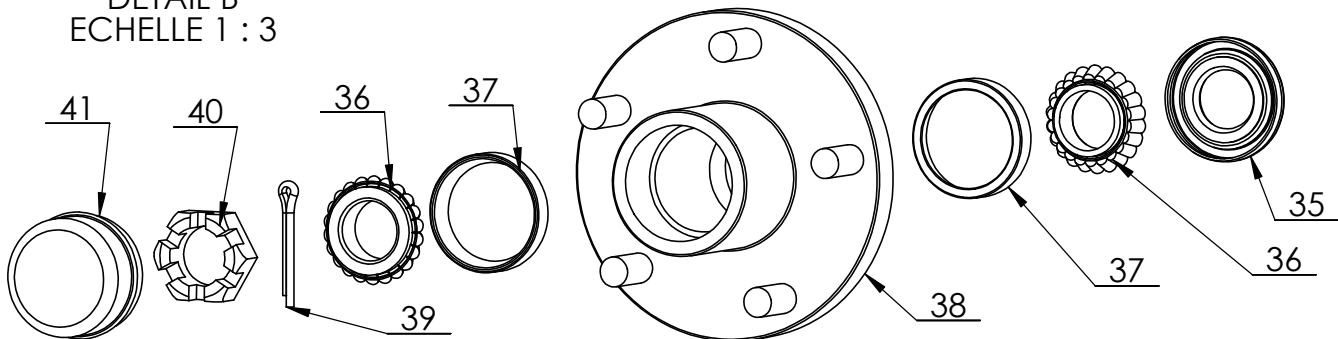



Parts list 4MCX Wood Splitter

Item	40-30 Part no	40-36 Part no	description	Qty
1	55-041-01	55-042-01	Wood splitter housing 4030	1
2	53-001-035	53-001-035	Battery box top	1
3	55-009-015	55-009-015	Bushing	2
4	55-023-03	55-023-03	4030 H-beam splitter release rod	1
5	55-009-031	55-009-031	Sled ram	2
7	55-024-03	55-024-03	15 US gallon tank	1
8	55-028-03	55-028-03	Knife assembly	1
9	55-028-04	55-028-04	Knife pendulum	1
10	55-028-05	55-028-05	Log lift arm assembly	1
11	55-028-002	55-027-02	transfer bar	1
12	55-041-03	55-042-03	4030 Wood splitter frame	1
13	55-041-30	55-041-30	Log lift assembly	1
14	55-001-31	55-001-31	Release adjustment handle	1
15	55-041-058	55-041-058	Swivel	2
16	55-041-02	55-041-02	Swivel	1
17	108020	108020	9 HP honda Motor	1
18	190036	190036	Hydraulic Valve	1
19	120851	120851	4" dia x 30" stroke hydraulic cylinder	1
20	302180	302180	Tire 20.5-8-10 6 ply, 5 nuts	2
21	106010	106010	Bell housing	1
22	190033	190033	Pump 4-16 gallons 212018 CUP CBN-13/4.2	1
23	190060	190060	Oil filter cap CP-750-10P	1
24	190050	190050	Oil filter CP-750-10P	1
25	190010	190010	Pre-Filtre LTM -15-100	1
26	303010	303010	3000-2000 Jack	1
27	140320	140320	L095- 1/2	1
28	55-001-18-PR	55-001-18-PR	Hydraulic valve assembly and release plate	1
29	140360	140360	Love joy insert L095	1
30	140340	140340	L095- 3/4	1
31	310670	310670	Hand	1
32	120280	120280	2-1/2" dia x 8" stroke hydraulic cylinder	1
33	400500	400500	Document holder	1
34	55-009-07	55-009-07	Ram	1
35	306005	306005	Hub seal 1250LBS	2
36	306003	306003	Bearing int/ext 1250lbs	4
37	306004	306004	Cone int/ext 1250lbs	4
38	306001	306001	Hub 1250lbs	2
39	306008	306008	Cotter pin	2
40	306007	306007	Hub nut 1250lbs	2
41	306006	306006	Dust cap 1250lbs	2



Operation

General safety rules and guidelines:

Read this instruction manual carefully before operating the wood splitter. The technical data in this manual also contains important information. Improper use can result in injury and damage to the equipment.

The use of a wood splitter requires a high level of experience and a good knowledge of operation. You must learn to know the behavior of the wood splitter and practice using it. Make sure no one is in the operator's working area when in use.

Woody wood splitters are intended for normal use in the agricultural and forestry sectors. They must be used only by persons trained in the handling of this type of machinery.

- Before using your Woody wood splitter, you must read the instruction manual, so as to perfectly control the operation.
- When operating, make sure no bystanders are in the work area. The user must have full visibility of the work area.
- Manipulate the logs by their center to place them on the splitting area, never handle the logs at their extremities, you could accidentally find your hands trapped between the knives and the log.



- When operating, do not insert your hand or any other part of your body into the machine. Do not risk getting stuck between the different parts of the splitter.
- When loading the logs with the log lifter you must keep your eyes on the log lifter to avoid being surprised by the rise of the log.
- Never use the log-loading device during transport.
- To stop the machine, lower the log lifter to a solid surface, turn off the engine, and remove the key from the ignition to prevent unauthorized use.
- The log lifter is not intended for lifting people.



Woody Wood Splitter General Maintenance Instructions

A hydraulic oil change is required only if there is contamination by water, other liquid or another contaminant.

For a hydraulic oil change, use only ISO 32 clear, and remember to change your hydraulic oil filter.

For an engine oil change, use 5W30 oil. Change every two years.

Before use each season

Check your wheel bearing and grease your wheel hubs.

Check the tire pressure 50lbs psi

Apply grease on the worktable to enable the knife to glide easily without restriction.



1-Year limited warranty

Warranty Qualifications

Les Équipements Woody inc. (hereinafter referred to as "Woody") warrants its products (hereinafter referred to as the "Product" against defects in material or factory workmanship, subject to all the terms and conditions stated herein.

All Products manufactured by Woody and used for domestic purposes (excluding commercial and industrial use) are covered by one (1) year warranty applicable from the purchase date, except in particular cases when the warranty might be modified according to adjustments specified on the sales contract.

The warranty extends only to the original purchaser (hereinafter referred to as the "Buyer") of the Product and not to other purchasers or transferees unless agreed to in writing by Woody that the mechanical and electrical components will be free of defects in material and workmanship for the warranty period. The warranty covers all the parts of the new Product, except the hydraulic hoses, the hydraulic fittings and the electrical wires, and includes the labor performed by Woody or by a Woody authorized dealer (hereinafter referred to as the "Dealer")

Warranty Repair and Replacement Service

All warranted repairs must be performed by Woody or by an authorized Dealer with the written consent of Woody, otherwise the warranty will be voided. Woody reserves the right to either repair or replace, without cost to the buyer any part judged defective on grounds of defective materials or workmanship. It also reserves the right to determine if the defect resulted from lack of maintenance or incorrect or abusive use of the Product.

In the event of any failure caused by a defect in material or in factory workmanship covered by this warranty, the Buyer shall: (1) notify Woody of the nature of the problem without delay; (2) stop using or operating the Product, unless authorized in writing by Woody.

Warranty service shall be performed at the point of purchase of the Product either by Woody or by a Dealer using parts provided by Woody.

If the Product was purchased directly from Woody, the Buyer shall return either the Product or the defective parts "prepaid" to Woody without delay. If Woody deems that the parts are in fact defective, it shall repair or replace the parts and, when the Product is returned to Woody, install them free of charge to the Buyer.

If the Product was purchased from a Dealer, Woody shall provide the replacement parts to the Buyer through the intermediary of the Dealer. The Dealer shall install the parts and return the replaced parts to Woody, "prepaid" by the Buyer, within thirty (30) days of the repairs. The parts and their installation shall be without charge to the Buyer providing that the replaced parts are proven defective to Woody's satisfaction.



No Dealer Warranty

In all cases, all costs related to the transportation of parts or of the Product to and from Woody or the Dealer, any premium charged for overtime labor requested by the Buyer or for any service and/or maintenance shall be the sole responsibility of the Buyer.

All parts replaced under the warranty shall remain the property of Woody.

If the Buyer fails to follow any of the above procedures or if the parts are not proven to be defective to Woody's satisfaction, the Buyer shall not benefit from the warranty.

No Dealer Warranty

The Dealer has no authority to make any representation or promise on behalf of Woody, or to modify the terms or limitations of this warranty in any way.

Warranty Exclusions

This warranty does not cover the following:

Product needs periodic parts and service to perform well. This warranty does not cover repair when normal use has exhausted the life of a part or the equipment as a whole or by lack of reasonable and proper maintenance, by lack of proper protection during storage, by failure to follow operating instructions and/or failure to operate the Product according to the specifications outlined by Woody.

This warranty does not apply to damage caused to the Product or machinery by the Buyer or Dealer during installation of the Product or due to improper installation of the Product.

This warranty will not apply to parts and/or labor if this Product is deemed to have been misused, neglected, involved in an accident, abused or defects caused by any alternation or modification of the Product not approved in writing by Woody.

This warranty does not cover travel time and does not cover any other transportation-related costs for warranty repairs or for any other expertise.

Other Exclusions

This warranty excludes:

- Cosmetic defects such as paint, decals, etc.
- Any damage resulting from overturning the machine.
- Failures due to acts of God and any other major force events beyond Woody's control.
- Problems caused by parts that are not original Woody parts.
- Certain parts are guaranteed by their respective manufacturer.

Limits of Implied Warranty and Consequential Damage

Woody disclaims any obligation to cover any material or personal damages, including loss of time, loss of income use of this Product, replacement rental, freight or any other damages caused by a defective Product or any incidental or consequential claim by anyone by from using this Product.