

COUPE A-A

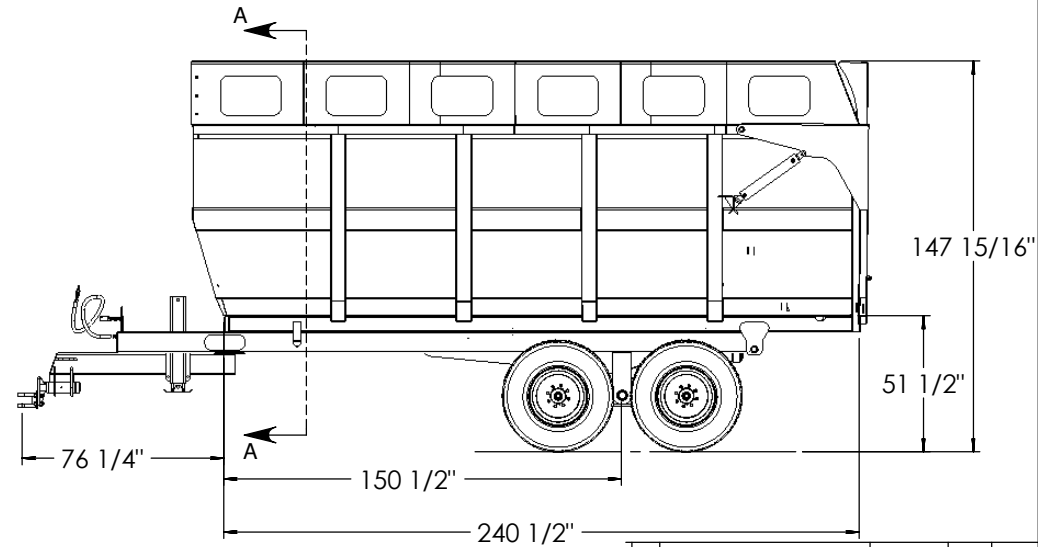

Dompeur 8 x 20 HD

Pneu 550-45 R22.5

Ass 50-016

PROCÉDÉ	INIT.	TEMPS
Assemblage		

DESSIN PAR:	VÉRIFIÉ PAR:	SIZE: A	TOLERANCES SI NON SPECIFIÉES
		UNITÉ: po.	XV ±1/16"
		ECHELLE: 1:50	.XX ±0.010"
			.XXX ±0.005"
			X* ±1"



# CNC:	
MATÉRIEL:	

FICHER : 50-016
CONFIG : Défaut

DESSIN : **50-016**
Boîte à ensilage 8 x 20

#	RÉVISION	DATE	PAR	APPR
0		1799-12-27		
0		1799-12-27		
1				
#				

Date d'impression:	25 juin 2019
REV.	00
P.	5 / 9