

COUPE H-H

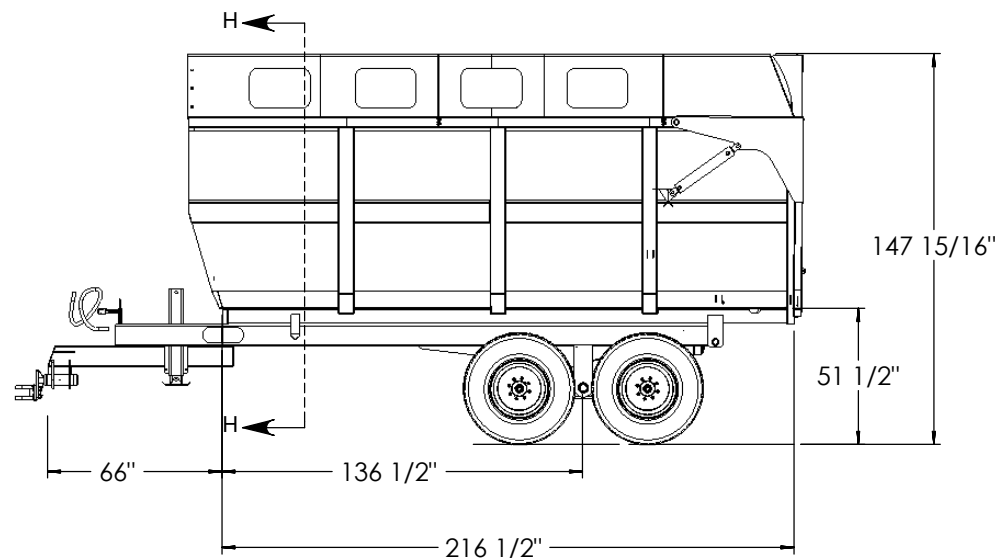

**QTE : 1X**

# Dompeur 8 x 18 HD

## Pneu 550-45 R22.5

### Ass 50-015

PROCÉDÉ	INIT.	TEMPS
Assemblage		

DESSIN PAR:	VÉRIFIÉ PAR:	SIZE:	<b>A</b>	TOLERANCES EN mm
		UNITÉ:	po.	XX ±0.010"
		ECHELLE:	1:50	XX ±0.005"
				X* ±1"



#	RÉVISION	DATE	PAR	APPR
0		1799-12-27		
0		1799-12-27		
1	79 fut 81	2019-09-05	M.B.	
#				

# CNC :	
MATÉRIEL :	

FICHER : 50-015	# DESSIN :	Date d'impression :
CONFIG : Défaut	<b>50-015</b>	25 juin 2019
	Boîte à ensilage 8 x 18	

REV.	00
P.	5 / 8